

LCA Series

In-Line Deflagration Flame Arresters



With Replaceable Element for NEC Explosion Gas Group D

The Protectoseal LCA Series prevents the spread of fire within piping systems. By installing an LCA Series in close proximity to the potential source of ignition, flames (or an explosion) are restricted to the immediate region.



Principle of Operation

The LCA Series cools the combustion products at the element surface during a deflagration without a stable flame. This technique prevents the combustion process from continuing through the LCA Series and into the protected line.

In the case that a flame stabilizes on the element surface of the LCA Series, a monitoring system will detect a fast increase in temperature and activate secondary protective measures to stop the flow of the flammable mixture.

Operating Conditions

The Protectoseal LCA Series is ATEX-approved for a maximum operating temperature of **140°F** or **60°C**. For high-temperature models, the maximum operating temperature is increased to **320°F** or **160°C**.

Explosion Gas Groups

The Protectoseal LCA Series is certified for gases in **NEC Group D** and **IEC Groups IIA1 and IIA**.

Standards Compliance

Protectoseal's LCA Series of In-Line Deflagration Flame Arresters has been type-tested to **EN ISO 16852** and approved according to **ATEX Directive 2014/34/EU**.

Each LCA that passes through Protectoseal's facilities undergoes a rigorous inspection and verification of its safety and performance features.

Protectoseal Expertise

Protectoseal offers industry leading technical leadership with its renowned flame and explosion protection for the most diverse and challenging of industrial applications. By utilizing a range of testing facilities, advanced algorithms and computational fluid dynamics (CFD), our research and development team is constantly looking for new ways to challenge the status quo, thus providing best-in-class innovation.

With over 95 years in the business, we have an established sales and service team to support clients with their initial specifications and throughout the product's life cycle.

Features and Benefits

- Outstanding flow capacity with minimal pressure drop
- Short-time burning proof capabilities
- The highest degree of bi-directional safety
- Elements feature replaceable, easy-to-clean crimped-ribbon
- Available with elevated operating temperature and pressure
- Sizes and materials to accommodate a vast array of applications
- Options for end connections include flanged or threaded

General Arrangements:

LCA Flame Arresters (inc. High Temperature)

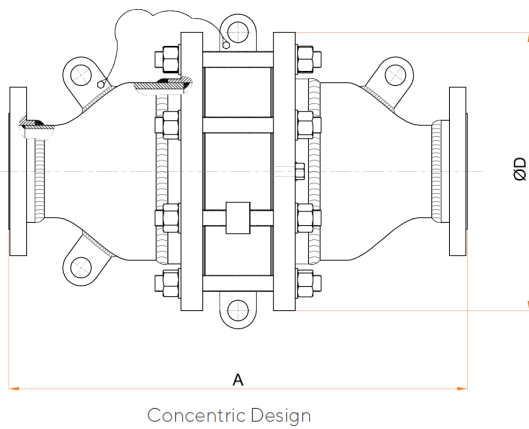

LCA Short-Time Burn Flame Arresters

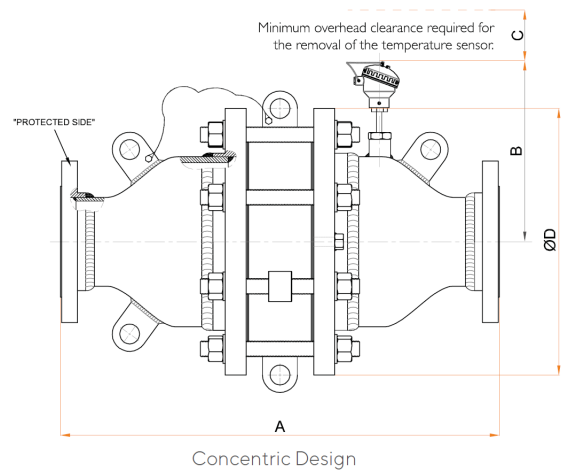

Ref	Description
A	Overall Length
B	Centre to Top of Temperature Probe (short-time burn models)
C	Minimum Clearance (short-time burn models)
D	Ø Diameter

Selection Key

Positions	1	2	3	4	5	6	7	8	9	10	11	12	13	14	15	16	17	18	19	20	21	22	23	24	25	26	27	28	29
Example	L	C	A	-	0	5	0	A	T	-	1	0	0	T	S	-	N	1	.	2	0	-	N	/	0	0	0	W	0
Table	a	b	c	-	d			e	f	-	g			h	j	-	k	l			-	m	/	n	o	p	q	r	
Model No.	L	C	A	-				A		-	X	X	X		S	-		1	.			-		/	0	0	0		0

Standard Options		
a	Flame Arrester Type	In-Line Deflagration
b	Model Variation	Concentric
c	Gas Group	D, IIA
d	Size	Refer to Table 1
e	Pipe Connection Type	ANSI 150lb. RF
f	Flame Arrester Housing Material	Refer to Table 2
g	Element Size	XXX <i>(Place Holder - your local Protectoseal representative will fill out this section for you)</i>
h	Element Housing Material	Refer to Table 3
j	Element Core Material	316/316L Stainless Steel
k	Temp Rating	Refer to Table 4
l	Operating Pressure Rating	Refer to Table 5
m	Short-Time Burn Capability	Refer to Table 6

Non-Standard Options		
n	Body Modification	Standard - No Alterations
o	Finish/Paint	Refer to Table 7
p	Gasket/Seal	CNAF
q	Fasteners	Refer to Table 8
r	Ports/Taps	Standard - No Ports/Taps

Table 1: Sizes

1.1 LCA With Standard Reducer

d	Size	Overall Length A	ØD	f	h	Approx Weight
040	1.5", 40mm	12.48", 317mm	9.02", 229mm	C or S	D or T	49lbs, 22kg
050	2", 50mm	12.72", 323mm	9.02", 229mm	D or T	D or T	53lbs, 24kg
080	3", 80mm	16.26", 413mm	10.98", 279mm	D or T	D or T	88lbs, 40kg
100	4", 100mm	17.99", 457mm	13.50", 343mm	D or T	D or T	139lbs, 63kg
150	6", 150mm	22.72", 577mm	19.02", 483mm	D or T	D or T	269lbs, 122kg
200	8", 200mm	35.55", 903mm	23.50", 597mm	D or T	D or T	474lbs, 215kg
250	10", 250mm	48.07", 1221mm	27.48", 698mm	D or T	D or T	703lbs, 310kg
300	12", 300mm	48.78", 1239mm	32.01", 813mm	D or T	D or T	917lbs, 416kg

1.2 LCA With Dish-End Reducer

d	Size	Overall Length A	ØD	f	h	Approx Weight
015	1/2", 0.5", 15mm	12.48", 317mm	9.02", 229mm	C or S	D or T	46lbs, 21kg
020	3/4", 0.75", 20mm	12.48", 317mm	9.02", 229mm	C or S	D or T	49lbs, 22kg
025	1", 25mm	13.27", 337mm	9.02", 229mm	C or S	D or T	49lbs, 22kg
040	1.5", 40mm	13.27", 337mm	9.02", 229mm	C or S	D or T	51lbs, 23kg
050	2", 50mm	13.27", 337mm	9.02", 229mm	D or T	D or T	55lbs, 25kg
080	3", 80mm	16.02", 407mm	10.98", 279mm	D or T	D or T	93lbs, 42kg
100	4", 100mm	18.15", 461mm	13.50", 343mm	D or T	D or T	141lbs, 64kg
150	6", 150mm	23.50", 597mm	19.02", 483mm	D or T	D or T	282lbs, 128kg
200	8", 200mm	27.20", 691mm	23.50", 597mm	D or T	D or T	450lbs, 204kg
250	10", 250mm	31.69", 805mm	27.48", 698mm	D or T	D or T	661lbs, 300kg
300	12", 300mm	36.18", 919mm	32.01", 813mm	D or T	D or T	915lbs, 415kg

Note: Dish-End models are available with larger elements for enhanced flow capabilities. Dimensions presented above are for 1.2bara operating pressure models.

1.3 LCA High Temperature With Standard Reducer

d	Size	Overall Length A	ØD	f	h	Approx Weight (kg)
015	1/2", 0.5", 15mm	12.87", 327mm	9.02", 229mm	C or S	D or T	46lbs, 21kg
020	3/4", 0.75", 20mm	12.87", 327mm	9.02", 229mm	C or S	D or T	49lbs, 22kg
025	1", 25mm	13.66", 347mm	9.02", 229mm	C or S	D or T	49lbs, 22kg
040	1.5", 40mm	12.87", 327mm	9.02", 229mm	C or S	D or T	49lbs, 22kg
050	2", 50mm	13.11", 333mm	9.02", 229mm	D or T	D or T	53lbs, 24kg
080	3", 80mm	16.65", 423mm	10.98", 279mm	D or T	D or T	93lbs, 42kg
100	4", 100mm	18.39", 467mm	13.50", 343mm	D or T	D or T	146lbs, 66kg
150	6", 150mm	23.11", 587mm	19.02", 483mm	D or T	D or T	276lbs, 125kg
200	8", 200mm	35.94", 913mm	23.50", 597mm	D or T	D or T	487lbs, 221kg
250	10", 250mm	48.46", 1231mm	27.48", 698mm	D or T	D or T	701lbs, 318kg
300	12", 300mm	49.17", 1249mm	32.01", 813mm	D or T	D or T	941lbs, 427kg

1.4 LCA High Temperature With Dish-End Reducer

d	Size	Overall Length A	ØD	f	h	Approx Weight
015	1/2", 0.5", 15mm	12.87", 327mm	9.02", 229mm	C or S	D or T	46lbs, 21kg
020	3/4", 0.75", 20mm	12.87", 327mm	9.02", 229mm	C or S	D or T	49lbs, 22kg
025	1", 25mm	13.66", 347mm	9.02", 229mm	C or S	D or T	49lbs, 22kg
040	1.5", 40mm	13.66", 347mm	9.02", 229mm	C or S	D or T	51lbs, 23kg
050	2", 50mm	13.66", 347mm	9.02", 229mm	C or S	D or T	55lbs, 25kg
080	3", 80mm	16.42", 417mm	10.98", 279mm	C or S	D or T	95lbs, 43kg
100	4", 100mm	18.54", 471mm	13.50", 343mm	C or S	D or T	148lbs, 67kg
150	6", 150mm	23.90", 607mm	19.02", 483mm	C or S	D or T	280lbs, 127kg
200	8", 200mm	27.60", 701mm	23.50", 597mm	C or S	D or T	463lbs, 210kg
250	10", 250mm	32.09", 815mm	27.48", 698mm	C or S	D or T	680lbs, 308kg
300	12", 300mm	36.57", 929mm	32.01", 813mm	C or S	D or T	939lbs, 426kg

Note: Dish-End models are available with larger elements for enhanced flow capabilities.

1.5 LCA Short-Time Burn With Standard Reducer

d	Size	Overall Length A	Centre to Top of Temperature Probe	Min C	ØD	f	h	Approx Weight
040	1.5", 40mm	12.48", 317mm	11.22", 285mm	2.95", 75mm	9.02", 229mm	C or S	D or T	51lbs, 23kg
050	2", 50mm	12.72", 323mm	11.22", 285mm	2.95", 75mm	9.02", 229mm	D or T	D or T	55lbs, 25kg
080	3", 80mm	17.99", 457mm	13.39", 340mm	2.95", 75mm	13.50", 343mm	D or T	D or T	141lbs, 64kg
100	4", 100mm	17.99", 457mm	13.39", 340mm	2.95", 75mm	13.50", 343mm	D or T	D or T	141lbs, 64kg
150	6", 150mm	22.72", 577mm	15.75", 400mm	5.31", 135mm	19.02", 483mm	D or T	D or T	271lbs, 123kg
200	8", 200mm	35.55", 903mm	17.13", 435mm	5.31", 135mm	23.50", 597mm	D or T	D or T	476lbs, 216kg
250	10", 250mm	48.07", 1221mm	19.09", 485mm	7.68", 195mm	27.48", 698mm	D or T	D or T	686lbs, 311kg
300	12", 300mm	48.78", 1239mm	21.06", 535mm	7.68", 195mm	32.01", 813mm	D or T	D or T	919lbs, 417kg

1.6 LCA Short-Time Burn With Dish-End Reducer

d	Size	Overall Length A	Centre to Top of Temperature Probe	Min C	ØD	f	h	Approx Weight
015	1/2", 0.5", 15mm	12.48", 317mm	11.22", 285mm	2.95", 75mm	9.02", 229mm	C or S	D or T	46lbs, 21kg
020	3/4", 0.75", 20mm	12.48", 317mm	11.22", 285mm	2.95", 75mm	9.02", 229mm	C or S	D or T	49lbs, 22kg
025	1", 25mm	13.27", 337mm	11.22", 285mm	2.95", 75mm	9.02", 229mm	C or S	D or T	49lbs, 22kg
040	1.5", 40mm	13.27", 337mm	11.22", 285mm	2.95", 75mm	9.02", 229mm	C or S	D or T	51lbs, 23kg
050	2", 50mm	13.27", 337mm	11.22", 285mm	2.95", 75mm	9.02", 229mm	D or T	D or T	55lbs, 25kg
080	3", 80mm	16.02", 407mm	8.86", 225mm	2.36", 60mm	9.02", 229mm	D or T	D or T	93lbs, 42kg
100	4", 100mm	18.15", 461mm	9.45", 240mm	2.36", 60mm	13.50", 343mm	D or T	D or T	141lbs, 64kg
150	6", 150mm	23.50", 597mm	11.02", 280mm	3.94", 100mm	19.02", 483mm	D or T	D or T	282lbs, 128kg
200	8", 200mm	27.20", 691mm	17.13", 435mm	5.31", 135mm	23.50", 597mm	D or T	D or T	450lbs, 204kg
250	10", 250mm	31.69", 805mm	19.09", 485mm	7.68", 195mm	27.48", 698mm	D or T	D or T	661lbs, 300kg
300	12", 300mm	36.18", 919mm	21.06", 535mm	7.68", 195mm	32.01", 813mm	D or T	D or T	915lbs, 415kg

Note: Dish-End models are available with larger elements for enhanced flow capabilities. Dimensions presented above are for 12bara operating pressure models.

Table 2: Flame Arrester Housing Materials

f	Flame Arrester Housing (Body) Material	o	q
C	Fabricated Carbon Steel	O	C
D	Cast Carbon Steel	O	C
S	Fabricated 316/316L Stainless Steel	F	W
T	Cast 316 Stainless Steel	F	W

Table 3: Element Housing Materials

h	Element Housing (Body) Material
C	Fabricated Carbon Steel
D	Cast Carbon Steel
S	Fabricated 316/316L Stainless Steel
T	Cast 316 Stainless Steel

Table 4: Temperature Rating

k	Temperature Rating
N	Standard (140°F, 60°C)
E	Max Elevated Temperature (320°F, 160°C)

Table 5: Operating Pressure Rating

l	Operating Pressure Rating
1.20	17.4 psia, 1.20 bara
1.45	21 psia, 1.45 bara

Table 6: Short-Time Burn Capability

m	Short-Time Burn Capability
N	No Capability
S	Short Time Burn Single Sensor
T	Short Time Burn Double Sensor (Bi-Directional)

Table 7: Finish/Paint

o	Finish/Paint
O	Primer & Top Coat Orange
F	Natural, Unpainted

Table 8: Fasteners

o	Finish/Paint
C	Zinc Plated Steel
W	316 Stainless Steel

Customer Support

Tel: 1.630.595.0800

Email: info@protectoseal.com

Fax: 1.630.595.8059

225 Foster Avenue Bensenville, IL 60106 U.S.A

