

# SERIES 25000 & 26000

## Bi-Directional Overdriven / Unstable Detonation Flame Arresters



- Sizes 2" (DN 50) through 18" (DN 450)
- Series 25000 for NEC Group D, IEC Group IIA Vapors
- Series 26000 for NEC Group D & C, IEC Groups IIA & IIB3 Vapors
- 150# ANSI standard, DIN PN16 optional
- Interchangeable elements minimize "down-time"
- Low pressure drop, less susceptible to clogging
- Optional connections for drains, pressure taps or temperature probes
- Available in Carbon Steel, Stainless Steel & Alloy C276



# SERIES 25000 26000

### OBJECTIVE

The Protectoseal Series 25000 & 26000 Detonation Arresters are specifically designed to withstand and arrest the high velocity and high pressure flame fronts that may develop in long or complex piping runs such as those encountered in vapor recovery or manifolded tank systems. The arresters provide positive protection against flame transmission through piping systems handling vapor mixtures as referenced in the National Electrical Code (NEC) Article 500:

**Series 25000** - Suitable for use with Group D vapors, generally equivalent to International Electrotechnical Commission (IEC) Group IIA.

**Series 26000** - Suitable for use with Groups D & C vapors, generally equivalent to International Electrotechnical Commission (IEC) Group IIA and IIB3.

### TECHNIQUE

When properly specified and installed, the Series 25000/26000 Bi-Directional Detonation Arresters are designed to stop deflagrations, stable detonations and overdriven/unstable detonations. The proven ability to withstand this variety of flame fronts is a key characteristic of a detonation flame arrester. These arresters are bi-directional, able to stop a flame approaching from either direction in the piping system.

The severity of the service conditions that the arrester must withstand is demonstrated by the fact that the stable detonation velocity of a flame front in a 4.3% propane/air mixture is 5,800 ft./sec. Instantaneous pressures at the flame front in excess of 500 PSIG have been recorded.

Series 25000/26000 Detonation Arresters are tested to stop and quench such a shock wave while retaining the integrity of both the arresting element and the housing. The size and shape of the openings in the crimped metal element and the length of passage through these openings have been designed to ensure the ability of the device to quench multiple stable and overdriven detonations as well as low speed deflagrations and stationary flames, with minimum pressure drop.

### SPECIAL FEATURES

The Series 25000/26000 Detonation Flame Arrester designs utilize crimped metal flame arrester elements. High strength, welded steel housing, hydrostatically tested at 475 PSIG. All welding is performed in accordance with ASME Boiler and Pressure Vessel Code Section IX.

**Configuration.** Concentric housing.

**Sizes Available.** 2" (DN 50) through 18" (DN 450) sizes. Flanged to mate with standard flanged 150# ANSI or DIN PN16 bolting specifications. Other drilling patterns are also available upon special request.

**Laboratory Testing & Approvals.** Protectoseal's Detonation Flame Arresters have been thoroughly tested by independent laboratories. Refer to dimension charts for specific test lab listings. For arresters that meet the latest ATEX Directive, ISO 16852, refer to Series 25000E/35000E and 26000E/36000E.

**PRO-FLOW® Sizing and Selection Software.** Use PRO-FLOW® to calculate flame arrester flow requirements in accordance with API 2000, ISO 28300, NFPA 30 and OSHA 1910.106.

**Optional Connections.** Flanged or threaded fittings may be provided on the arrester housing for drains, pressure taps or temperature probes if required.

**Precision Manufacturing.** The ability to control the size of the element openings is the key to arresting high velocity and high pressure flame fronts. Manufactured under Protectoseal's ISO 9001 Quality System.

### CONSTRUCTION

A comprehensive range of materials is offered as shown in the chart below.

Series	Housing & Element Housing	Element Winding
C25000 / C26000	Steel	316 S.S.
CL25000 / CL 26000	Steel	304 S.S.
F25000 / F26000	316 S.S.	316 S.S.
FL25000 / FL26000	316 S.S.	304 S.S.
L25000 / L26000	304 S.S.	304 S.S.
M25000 / M26000	Alloy C276	Alloy C276

*All units flanged to mate with 150# R.F. ANSI. DIN flanging optional.*

## Series No. 25000

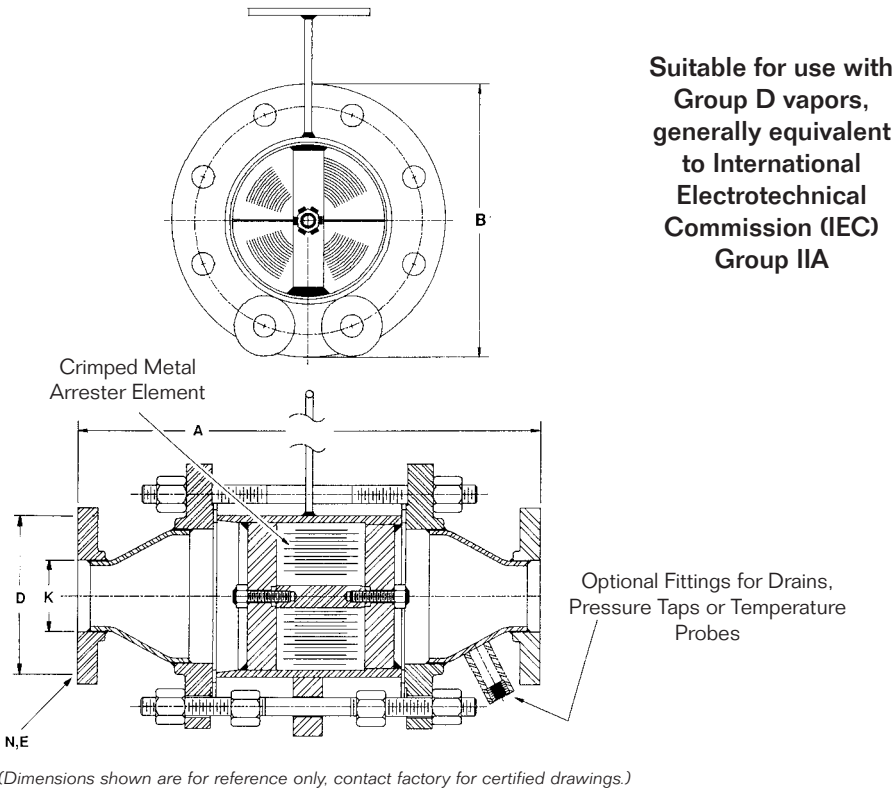

### DIMENSIONS AND ORDERING INFORMATION (Refer to Materials of Construction chart below to complete Cat. No.)

Cat. No.	Flange Size K	Face to Face A	Dia. B	B.C. D	Dia. E	Holes N	Test Lab Listings*		
							UL	ULC	USCG
25002	2"	15 <sup>7</sup> / <sub>8</sub> "	9"	4 <sup>3</sup> / <sub>4</sub> "	3 <sup>3</sup> / <sub>4</sub> "	4	C   F	C   F	C   CL   F   FL   L
25003	3"	19 <sup>3</sup> / <sub>4</sub> "	11"	6"	3 <sup>3</sup> / <sub>4</sub> "	4	C   F	C   F	C   CL   F   FL   L
25004A	4"	24 <sup>3</sup> / <sub>8</sub> "	13 <sup>1</sup> / <sub>2</sub> "	7 1/2"	3 <sup>3</sup> / <sub>4</sub> "	8	C   F	C   F	C   CL   F   FL   L
25006	6"	28 <sup>7</sup> / <sub>8</sub> "	19"	9 1/2"	7 <sup>7</sup> / <sub>8</sub> "	8	C   F	C   F	C   CL   F   FL   L
25008	8"	44"	23 <sup>1</sup> / <sub>2</sub> "	11 <sup>3</sup> / <sub>4</sub> "	7 <sup>7</sup> / <sub>8</sub> "	8	-	-	C   CL   F   FL   L
25010	10"	57 <sup>1</sup> / <sub>4</sub> "	27 <sup>1</sup> / <sub>2</sub> "	14 <sup>1</sup> / <sub>4</sub> "	1"	12	-	-	C   CL   F   FL   L
25012	12"	58"	32"	17"	1"	12	-	-	C   CL   F   FL   L
25014A	14"	73 <sup>5</sup> / <sub>8</sub> "	38 <sup>3</sup> / <sub>4</sub> "	18 <sup>3</sup> / <sub>4</sub> "	1 <sup>1</sup> / <sub>8</sub> "	12	-	-	C   CL   F   FL   L
25016A	16"	81 <sup>5</sup> / <sub>8</sub> "	38 <sup>3</sup> / <sub>4</sub> "	21 <sup>1</sup> / <sub>4</sub> "	1 <sup>1</sup> / <sub>8</sub> "	16	-	-	C   CL   F   FL   L
25018A	18"	83 <sup>1</sup> / <sub>8</sub> "	46"	22 <sup>3</sup> / <sub>4</sub> "	1 <sup>1</sup> / <sub>4</sub> "	16	-	-	C   CL   F   FL   L

\*Test Lab Listings - UL, Underwriters Laboratories, NEC Group D Vapor Equivalent; ULC, Underwriters Laboratories of Canada, NEC Group D Vapor Equivalent; USCG, United States Coast Guard, .90MM MESG (Min).

### MATERIALS OF CONSTRUCTION (All units flanged to mate with 150# R.F. ANSI. DIN flanging optional.)

Series No.	Material Prefix Code	Arrester Housing	Element Housing	Element Winding
C25000	C	Steel	Steel	316 S.S.
CL25000	CL	Steel	Steel	304 S.S.
F25000	F	316 S.S.	316 S.S.	316 S.S.
FL25000	FL	316 S.S.	316 S.S.	304 S.S.
L25000	L	304 S.S.	304 S.S.	304 S.S.
M25000	M	Alloy C276	Alloy C276	Alloy C276

**Series No. 26000**

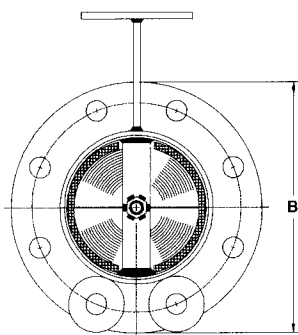

Suitable for use with  
 Group D & C vapors,  
 generally equivalent to  
 International  
 Electrotechnical  
 Commission (IEC)  
 Group IIA & IIB3

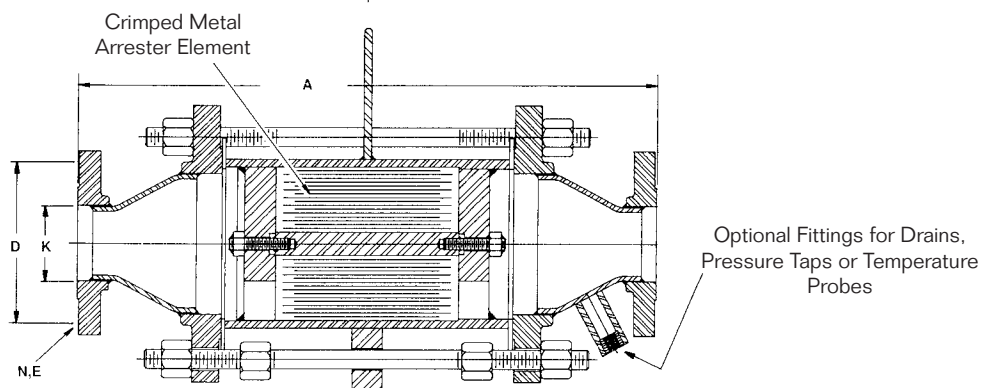

(Dimensions shown are for reference only, contact factory for certified drawings.)

**DIMENSIONS AND ORDERING INFORMATION** (Refer to Materials of Construction chart below to complete Cat. No.)

Cat. No.	Flange Size K	Face to Face A	Dia. B	B.C. D	Dia. E	Holes N	Test Lab Listing*	
							FM	USCG
26002	2"	18 <sup>7</sup> / <sub>8</sub> "	9"	4 <sup>3</sup> / <sub>4</sub> "	3 <sup>3</sup> / <sub>4</sub> "	4	C   F	C   CL   F   FL   L
26003	3"	22 <sup>3</sup> / <sub>4</sub> "	11"	6"	3 <sup>3</sup> / <sub>4</sub> "	4	C   F	C   CL   F   FL   L
26004	4"	24 <sup>3</sup> / <sub>8</sub> "	13 <sup>1</sup> / <sub>2</sub> "	7 <sup>1</sup> / <sub>2</sub> "	3 <sup>3</sup> / <sub>4</sub> "	8	C   F	C   CL   F   FL   L
26006	6"	28 <sup>7</sup> / <sub>8</sub> "	19"	9 <sup>1</sup> / <sub>2</sub> "	7 <sup>7</sup> / <sub>8</sub> "	8	C   F	C   CL   F   FL   L
26008	8"	44"	23 <sup>1</sup> / <sub>2</sub> "	11 <sup>3</sup> / <sub>4</sub> "	7 <sup>7</sup> / <sub>8</sub> "	8	-	C   CL   F   FL   L
26010	10"	57 <sup>1</sup> / <sub>4</sub> "	27 <sup>1</sup> / <sub>2</sub> "	14 <sup>1</sup> / <sub>4</sub> "	1"	12	-	C   CL   F   FL   L
26012	12"	58"	32"	17"	1"	12	-	C   CL   F   FL   L

*Material Prefix Code (Refer to chart below)*

Consult factory for larger sizes

\*Test Lab Listings - FM, Factory Mutual Research, NEC Group C & Group D Vapor Equivalent; USCG, United States Coast Guard, .65MM MESG (Min.).

**MATERIALS OF CONSTRUCTION** (All units flanged to mate with 150# R.F. ANSI, DIN flanging optional.)

Series. No.	Material Prefix Code	Arrester Housing	Element Housing	Element Winding
C26000	C	Steel	Steel	316 S.S.
CL26000	CL	Steel	Steel	304 S.S.
F26000	F	316 S.S.	316 S.S.	316 S.S.
FL26000	FL	316 S.S.	316 S.S.	304 S.S.
L26000	L	304 S.S.	304 S.S.	304 S.S.
M26000	M	Alloy C276	Alloy C276	Alloy C276

**PROTECTOSEAL DETONATION ARRESTER APPLICATION WORKSHEET**

<b>COMPANY:</b>		<b>DATE:</b>	
<b>PHONE:</b>		<b>ISSUED BY:</b>	
<b>FAX:</b>		<b>ADDRESS:</b>	
<b>E-MAIL:</b>			
<b>PROJECT:</b>			

*Please Specify Units of Measurement*

**SERVICE CONDITIONS**

1	Tag Number				
2	Tank Number				
3	Capacity of Tank				
4	Tank Design Pressure				
5	Tank Design Vacuum				
6	Gas / Vapor % or ppm				
	Gas / Vapor % or ppm				
	Gas / Vapor % or ppm				
	Gas / Vapor % or ppm				
	Gas / Vapor % or ppm				
	Gas / Vapor % or ppm				
	Gas / Vapor % or ppm				
7	Specify by Weight or Volume				
8	Molecular Weight Average				
9	Vapor Group NEC or IEC Rating				
10	Flash Point F				
11	Temperature F Operating / Maximum	/	/	/	/
12	Pressure Operating / Maximum	/	/	/	/

**DETONATION ARRESTER APPLICATION**

13	Deflagrations & Stable Detonations				
14	Deflagrations, Stable & Unstable (Overdriven Detonations)				
15	Distance between Arrester & Ignition Source				
16	List Bends between Arrester & Ignition Source				
17	Additional Information				

**FLOW REQUIREMENTS**

18	Flow Requirements				
19	Allowable Pressure Drop Across Arrester				

**MATERIALS OF CONSTRUCTION**

20	Body Material				
21	Arrester Element Winding				
22	Arrester Element Housing				

**DESIGN TYPE**

23	Vertical or Horizontal Installation				
24	Size: Inlet / Outlet	/	/	/	/
25	Connection Type				
26	Drain Plugs (qty / size/ NPT or flanged)				
27	Other Options				

**RECOMMENDATION**

28	Protectoseal Model Number				
----	---------------------------	--	--	--	--



225 Foster Ave., Bensenville, IL 60106-1690  
 P 630.595.0800 F 630.595.8059  
 info@protectoseal.com www.protectoseal.com