

# ERB Series

## End-of-Line Deflagration Flame Arresters



### Utilizing industry-leading RE-Flow® technology

The Protectoseal ERB Series prevents atmospheric deflagrations from entering a gas piping system, a vapor piping system, or a storage tank.



### Principle of Operation

The ERB Series flame arresting elements feature Protectoseal's E-Flow® (Enhanced Crimped Ribbon Technology). The optimized channel dimensions of the element offer unmatched deflagration protection, while maximizing flow performance and minimizing maintenance.

During deflagration, heat dissipation cools the combustion products at the element surface, preventing the fire from spreading past the ERB Series and into the protected vent line.

The ERB Series permits downward venting (RE-Flow®) as well as self-draining of the arrester element. This guarantees minimal element clogging or plugging under normal operating conditions.

### Operating Conditions

The Protectoseal ERB Series is ATEX-approved for operating temperatures between **140°F** or **60°C**.

### Explosion Gas Groups

The Protectoseal ERB Series is certified for gases in **NEC Group C** and **IEC Group IIB3**.

### Standards Compliance

Protectoseal's ERB Series of End-of-line Deflagration Flame Arresters has been type-tested to **EN ISO 16852** and approved according to **ATEX Directive 2014/34/EU**.

Each ERB that passes through Protectoseal's facilities undergoes a rigorous inspection and verification of its safety and performance features.

### Protectoseal Expertise

Protectoseal offers industry leading technical leadership with its renowned flame and explosion protection for the most diverse and challenging of industrial applications. By utilizing a range of testing facilities, advanced algorithms and computational fluid dynamics (CFD), our research and development team is constantly looking for new ways to challenge the status quo, thus providing best-in-class innovation.

With over 95 years in the business, we have an established sales and service team to support clients with their initial specifications and throughout the product's life cycle.

## Features and Benefits

- Simple, compact, sturdy, and lightweight
- Up to five times lighter than conventional flanged arresters
- Self-draining element prevents the entry of foreign matter
- Sizes and materials to accommodate a vast array of applications
- E-Flow® element maximizes flow performance
- Options for end connections include flanged or threaded
- Easy visual inspection of the element in situ

## General Arrangements:

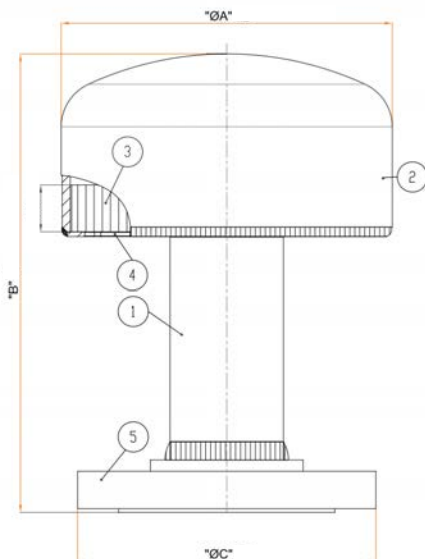
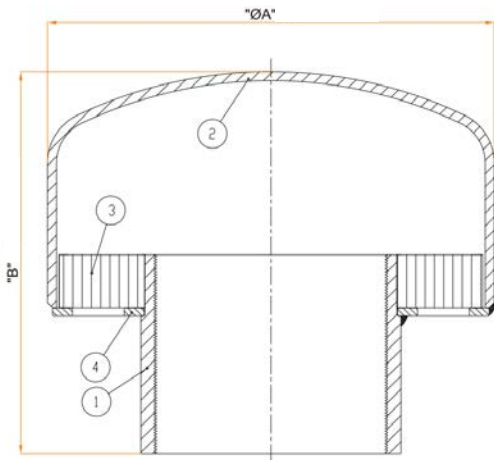

Ref	Description	Material	
1	Female Socket	Stainless Steel	
2	End Cap	Stainless Steel	
3	Crimped Ribbon Element	Stainless Steel	
4	Element Ring	Stainless Steel	
Dimensions			
d	ØA	B	Approx Weight
25	3.50", 89mm	3.23", 82mm	2lbs, 0.7kg
40	5.55", 141mm	4.21", 107mm	4lbs, 1.9kg
50	5.55", 141mm	4.57", 116mm	4lbs, 1.9kg
80	6.61", 168mm	5.67", 144mm	7lbs, 3.0kg

Ref	Description	Material		
1	Pipe	Stainless Steel		
2	End Cap	Stainless Steel		
3	Crimped Ribbon Element	Stainless Steel		
4	Element Ring	Stainless Steel		
5	Connection Flange	Stainless Steel		
Dimensions				
d	ØA	B	ØC	Approx Weight
25	3.50", 89mm	6.50", 165mm	4.53", 115mm	4lbs, 1.7kg
40	5.55", 141mm	7.68", 195mm	5.91", 150mm	8lbs, 3.5kg
50	5.55", 141mm	7.68", 195mm	6.50", 165mm	10lbs, 4.4kg
80	6.61", 168mm	8.46", 215mm	7.87", 200mm	16lbs, 7.4kg

## Selection Key

Positions	1	2	3	4	5	6	7	8	9	10	11	12	13	14	15	16	17	18	19	20	21	22	23	24	25	26	27	28	29
Example	E	R	B	-	0	5	0	A	T	-	1	0	0	S	S	-	N	1	.	0	0	-	N	/	W	F	N	0	0
Table	a	b	c	-	d			e	f	-	g			h	j	-	k	l			-	m	/	n	o	p	q	r	
Model No.	E	R	B	-					S	-	X	X	X	S	S	-	N	1	.	0	0	-	N	/	W	F	N	0	0

Standard Options		
a	Flame Arrester Type	End-of-Line Deflagration
b	Model Variation	Reverse Flow
c	Gas Group	C, IIB3
d	Size	Refer to Table 1
e	Pipe Connection Type	Refer to Table 2
f	Flame Arrester Housing Material	316/316L Stainless Steel
g	Element Size	XXX <i>(Place Holder - your local Protectoseal representative will fill out this section for you)</i>
h	Element Housing Material	316/316L Stainless Steel
j	Element Core Material	316/316L Stainless Steel
k	Temp Rating	Standard (140°F, 60°C)
l	Operating Pressure Rating	Atmospheric Pressure (14.7 psia, 1.01 bara)
m	Short-Time Burn Capability	Factory Reserved <i>(Refer to ESA Series for short-time burn Flame Arresters)</i>

Non-Standard Options		
n	Body Modification	Butt Weld End Cap Weather Hood
o	Finish/Paint	Natural, Unpainted
p	Gasket/Seal	Not Applicable - None Required
q	Fasteners	Not Applicable - None Required
r	Ports/Taps	Not Applicable - None Required

Table 1: Sizes

d	Size
025	1", 25 mm
040	1.5", 40 mm
050	2", 50 mm
080	3", 80 mm

**Note:** Refer to general arrangement drawings for dimensions.

Table 2: Pipe Connection Type

o	Type
A	B16.5 ASME CL.150 Raised Face Slip-On ( <b>RFSO</b> )
F	BS EN10241 <b>CL.150 NPT Female</b> Screw Thread (Ref. BS1740)

## Customer Support

Tel: 1.630.595.0800

Email: [info@protectoseal.com](mailto:info@protectoseal.com)

Fax: 1.630.595.8059

225 Foster Avenue Bensenville, IL 60106 U.S.A

