

UCA Series

In-Line Detonation Flame Arresters



With Concentric Body and Replaceable Element for NEC Explosion Gas Group D

The Protectoseal UCA Series prevents the propagation of gas or vapor explosions in pipelines under the harshest conditions, including unstable detonation, stable detonation, and deflagration.



Principle of Operation

The UCA Series combines Protectoseal's HEDS® (High Energy Dissipation System) and E-Flow® (Enhanced Crimped Ribbon Technology) to mitigate the effects of an explosion by preventing its spread.

The UCA Series utilizes a crimped ribbon element that allows gas or vapor to pass through with minimal pressure loss.

The UCA Series conforms to Protectoseal's long-term strategy for the protection of both plant and personnel, while maintaining market-leading flow versus pressure drop performance.

Operating Conditions

The Protectoseal UCA Series is ATEX-approved for a maximum operating temperature of **140°F** or **60°C**. For high-temperature models, the maximum operating temperature is increased to **302°F** or **150°C**.

Explosion Gas Groups

The Protectoseal UCA Series is certified for gases in **NEC Group D** and **IEC Group IIA**.

Standards Compliance

Protectoseal's UCA Series of In-Line Detonation Flame Arresters has been type-tested to **EN ISO 16852** and approved according to **ATEX Directive 2014/34/EU**.

Each UCA that passes through Protectoseal's facilities undergoes a rigorous inspection and verification of its safety and performance features.

Protectoseal Expertise

Protectoseal offers industry leading technical leadership with its renowned flame and explosion protection for the most diverse and challenging of industrial applications. By utilizing a range of testing facilities, advanced algorithms and computational fluid dynamics (CFD), our research and development team is constantly looking for new ways to challenge the status quo, thus providing best-in-class innovation.

With over 95 years in the business, we have an established sales and service team to support clients with their initial specifications and throughout the product's life cycle.

Features and Benefits

- Outstanding flow capacity with minimal pressure drop
- Short-time burn capabilities
- Bi-directional protection
- Elements feature replaceable, easy-to-clean crimped-ribbon
- Superior performance reduces ongoing expenses
- Unique element design is less prone to fouling and clogging
- No placement restrictions or additional protection required
- Sizes and materials to accommodate a vast array of applications
- Options for end connections include flanged or threaded
- Lightweight for installation convenience

Lightweight element design

By removing the fasteners that hold the element between the internal flanges, the element housing can be quickly disassembled.

Labelled element banks*

To ensure proper realignment after cleaning, each element is clearly labelled with its housing position.

Separate elements for complete access

Once the element housing has been disengaged, the central bolt (not shown) can be removed to facilitate the cleaning of individual element banks.

Reduced fouling design

The optimized element banks minimize flow resistance, reduce fouling and clogging, and permit condensate drainage.

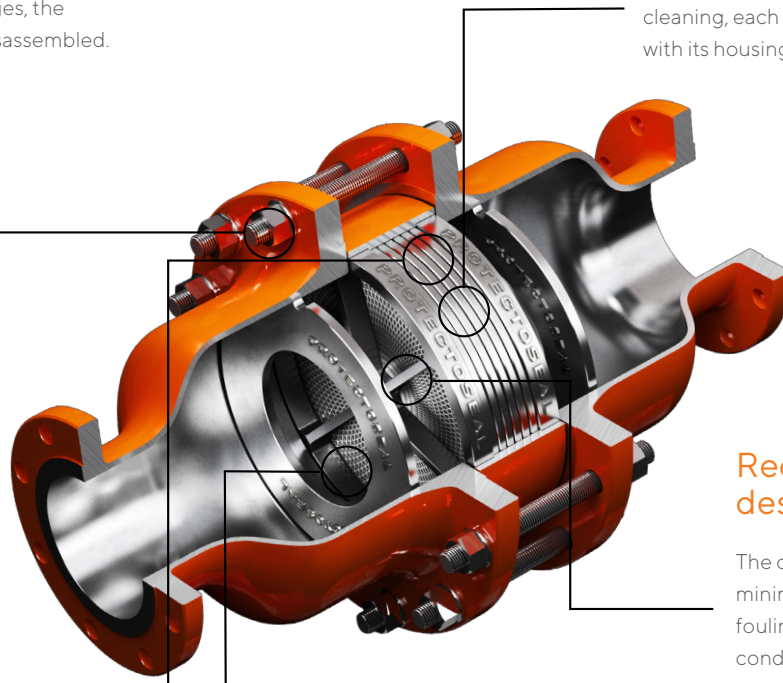

HEDS® (High Energy Dissipation System)

Protectoseal's innovative HEDS® technology functions as both a shock-attenuation system and an energy baffle, extending the UCA Series' ability to contain an explosion and enhancing the arrester's effectiveness. Additionally, the design protects the element from debris, thereby extending the maintenance interval.

* When removing, cleaning, and replacing element banks, it is vital that the installation, operation, and maintenance instructions (IOMs) provided by the manufacturer are strictly adhered to.

General Arrangements:

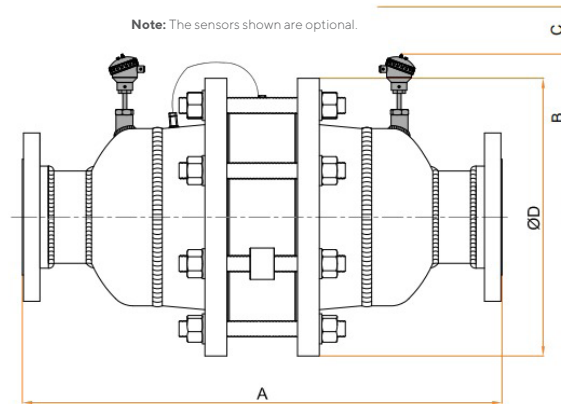

Selection Key

Positions	1	2	3	4	5	6	7	8	9	10	11	12	13	14	15	16	17	18	19	20	21	22	23	24	25	26	27	28	29
Example	U	C	A	-	0	5	0	A	T	-	1	0	0	T	S	-	N	1	.	2	0	-	N	/	0	0	0	W	0
Table	a	b	c	-	d			e	f	-	g			h	j	-	k	l			-	m	/	n	o	p	q	r	
Model No.	U	C	A	-				A		-	X	X	X		S	-		1	.			-		/	0		0		0

Standard Options		
a	Flame Arrester Type	Unstable In-Line Detonation
b	Model Variation	Concentric
c	Gas Group	D, IIA
d	Size	Refer to Table 1
e	Pipe Connection Type	ANSI 150lb. RF
f	Flame Arrester Housing Material	Refer to Table 2
g	Element Size	XXX <i>(Place Holder - your local Protectoseal representative will fill out this section for you)</i>
h	Element Housing Material	Refer to Table 3
j	Element Core Material	316/316L Stainless Steel
k	Temp Rating	Refer to Table 4
l	Operating Pressure Rating	Refer to Table 5
m	Short-Time Burn Capability	Refer to Table 6

Non-Standard Options		
n	Body Modification	Standard - No Alterations
o	Finish/Paint	Refer to Table 7
p	Gasket/Seal	CNAF
q	Fasteners	Refer to Table 8
r	Ports/Taps	Standard - No Ports/Taps

Table 1: Sizes

d	Size	Max Operating Pressure	Max Operating Temperature	Overall Length A	ØD	B (Short-Time Burn Models)	Min C	f	h	Approx Weight
025	1", 25 mm	17.4psia, 1.20bara 20.3psia, 1.40bara 23.2psia, 1.60bara	140°F, 60°C 302°F, 150°C 140°F, 60°C	17.76", 451mm 18.54", 471mm 18.54", 471mm	9.02", 229mm	11.22", 285mm	3.00", 75mm	C or S	D or T	62lbs, 28kg
040	1.5", 40 mm	17.4psia, 1.20bara 20.3psia, 1.40bara 23.2psia, 1.60bara	140°F, 60°C 302°F, 150°C 140°F, 60°C	17.76", 451mm 18.54", 471mm 18.54", 471mm	9.02", 229mm	11.22", 285mm	3.00", 75mm	C or S	D or T	62lbs, 28kg
050	2", 50 mm	17.4psia, 1.20bara 20.3psia, 1.40bara 23.2psia, 1.60bara	140°F, 60°C 302°F, 150°C 140°F, 60°C	17.76", 451mm 18.54", 471mm 18.54", 471mm	9.02", 229mm	11.22", 285mm	3.00", 75mm	D or T	D or T	62lbs, 28kg
080	3", 80 mm	17.4psia, 1.20bara 20.3psia, 1.40bara 21.76psia, 1.50bara	140°F, 60°C 302°F, 150°C 140°F, 60°C	22.87", 581mm 23.27", 591mm 23.27", 591mm	10.98", 279mm	12.40", 315mm	3.00", 75mm	D or T	D or T	119lbs, 54kg
100	4", 100 mm	17.4psia, 1.20bara 20.3psia, 1.40bara 21.76psia, 1.50bara	140°F, 60°C 302°F, 150°C 140°F, 60°C	25.16", 639mm 25.55", 649mm 25.55", 649mm	13.50", 343mm	13.39", 340mm	3.00", 75mm	D or T	D or T	181lbs, 82kg
150	6", 150 mm	16psia, 1.10bara 19psia, 1.30bara	140°F, 60°C 302°F, 150°C	25.24", 641mm 26.02", 661mm	19.02", 483mm	11.02", 280mm	3.94", 100mm	D or T	D or T	335lbs, 152kg
200	8", 200 mm	16psia, 1.10bara	140°F, 60°C	29.49", 749mm	23.50", 597mm	17.13", 435mm	5.31", 135mm	D or T	D or T	602lbs, 273kg
250	10", 250 mm	17.4psia, 1.20bara	140°F, 60°C	35.47", 901mm	27.48", 698mm	19.09", 485mm	7.68", 195mm	D or T	D or T	926lbs, 420kg
300	12", 300 mm	17.4psia, 1.20bara	140°F, 60°C	40.75", 1035mm	32.01", 813mm	21.06", 535mm	7.68", 195mm	D or T	D or T	1387lbs, 629kg
350	14", 350 mm	16psia, 1.10bara 16psia, 1.10bara	140°F, 60°C 302°F, 150°C	51.57", 1310mm 51.97", 1320mm	36.50", 927mm	23.03", 585mm	7.68", 195mm	C or S	C or S	2154lbs, 977kg
400	16", 400 mm	16psia, 1.10bara 16psia, 1.10bara	140°F, 60°C 302°F, 150°C	54.13", 1375mm 54.53", 1385mm	41.73", 1060mm	25.00", 635mm	7.68", 195mm	C or S	C or S	3012lbs, 1366kg
450	18", 450mm	16psia, 1.10bara	140°F, 60°C	58.11", 1476mm	45.98", 1168mm	27.05", 687mm	8.46", 215mm	C or S	C or S	3649lbs, 1655kg
500	20", 500mm	16psia, 1.10bara	140°F, 60°C	70.31", 1786mm	59.49", 1511mm	33.07", 840mm	14.76", 375mm	C or S	C or S	7066lbs, 3205kg
600	24", 600mm	16psia, 1.10bara	140°F, 60°C	70.31", 1786mm	59.49", 1511mm	33.07", 840mm	14.76", 375mm	C or S	C or S	7172lbs, 3253kg

Note: Alternative flange configuration options available on request. The weights are expressed in standard units (short time burn, high temperature and high pressure variants may vary).

Table 2: Flame Arrester Housing Materials

f	Flame Arrester Housing (Body) Material	o	q
C	Fabricated Carbon Steel	O	C
D	Cast Carbon Steel	O	C
S	Fabricated 316/316L Stainless Steel	F	W
T	Cast 316 Stainless Steel	F	W

Table 3: Element Housing Materials

h	Element Housing (Body) Material
C	Fabricated Carbon Steel
D	Cast Carbon Steel
S	Fabricated 316/316L Stainless Steel
T	Cast 316 Stainless Steel

Table 4: Temperature Rating

k	Temperature Rating
N	Standard (140°F, 60°C)
E	Max Elevated Temperature (302°F, 150°C)

Table 5: Operating Pressure Rating

l	Operating Pressure Rating
1.10	16 psia, 1.10 bara
1.20	17.4 psia, 1.20 bara
1.40	20.3 psia, 1.40 bara
1.50	21.76 psia, 1.50 bara
1.60	23.2 psia, 1.60 bara

Table 6: Short-Time Burn Capability

m	Short-Time Burn Capability
N	No Capability
S	Short-Time Burn Single Sensor
T	Short Time Burn Double Sensor (Bi-directional)

Table 7: Finish/Paint

o	Finish/Paint
O	Primer & Top Coat Orange
F	Natural, Unpainted

Table 8: Fasteners

q	Fasteners
C	Zinc Plated Steel
W	316 Stainless Steel

Customer Support

Tel: 1.630.595.0800
 Email: info@protectoseal.com
 Fax: 1.630.595.8059
 225 Foster Avenue Bensenville, IL 60106 U.S.A

