

# IS-3W SERIES 3-WAY BALL VALVES

## PNEUMATIC ACTUATORS

### PNEUMATIC FEATURES

- Rack and pinion design
- NAMUR accessory mounting
- Spring return and double acting
- Visual indicators
- Optional SS construction

ALL STANDARD ACTUATORS SIZED FOR 80 PSI AIR SUPPLY; PLEASE CONSULT FACTORY FOR OTHER COMBINATIONS

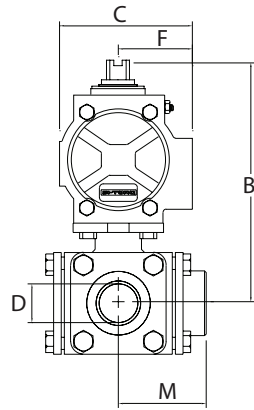
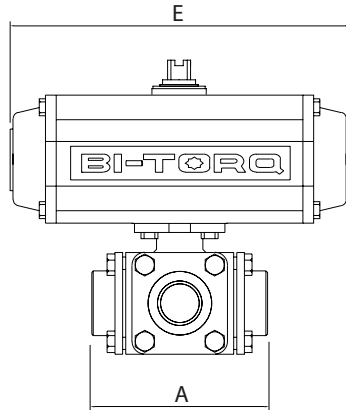

FOR A LIST OF AUTOMATION ACCESSORIES WE CAN OFFER, PLEASE REFER TO PAGE 31 OR VISIT BITORQ.COM

DOUBLE ACTING ASSEMBLY DIMENSIONS								
D	A	B	C	E	F	M	ACT.	WT.
1/2"	3.78	5.40	2.79	5.49	1.61	1.89	52DA	6.2
3/4"	4.21	5.81	2.79	5.49	1.61	2.11	52DA	7.85
1"	4.96	6.04	2.79	5.49	1.61	2.48	52DA	11.85
1-1/4"	5.24	7.07	3.17	6.38	1.77	2.62	63DA	14.2
1-1/2"	5.94	8.09	3.72	8.15	2.07	2.97	75DA	24.05
2"	6.54	8.78	3.72	8.15	2.07	3.27	75DA	28.85

SPRING RETURN ASSEMBLY DIMENSIONS								
D	A	B	C	E	F	M	ACT.	WT.
1/2"	3.78	5.40	2.79	5.49	1.61	1.89	52SR	6.55
3/4"	4.21	6.25	3.17	6.38	1.77	2.11	63SR	9.6
1"	4.96	7.13	3.72	8.15	2.07	2.48	75SR	15.9
1-1/4"	5.24	7.72	3.72	8.15	2.07	2.62	75SR	18.95
1-1/2"	5.94	9.05	4.85	10.69	2.68	2.97	100SR	32.9
2"	6.54	10.92	5.39	12.91	2.87	3.27	115SR	45.6

## ELECTRIC ACTUATORS

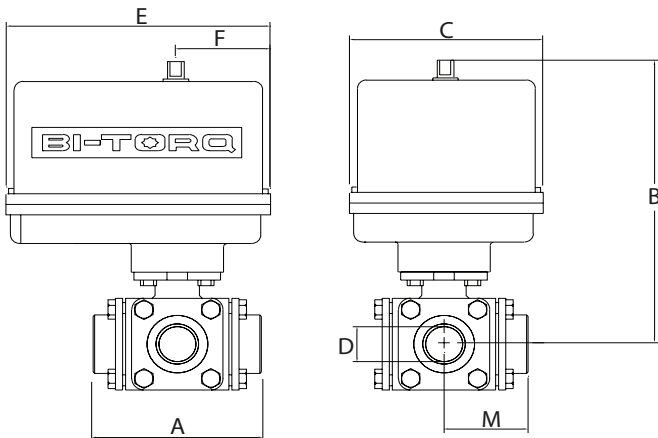

NEMA 4 ELECTRIC ASSEMBLY DIMENSIONS								
D	A	B	C	E	F	M	ACT.	WT.
1/2"	3.78	6.76	4.00	5.63	2.30	1.89	100E	8.90
3/4"	4.21	8.17	4.25	6.88	2.43	2.11	200E	12.65
1"	4.96	8.40	4.25	6.88	2.43	2.48	200E	15.85
1-1/4"	5.24	8.99	4.25	6.88	2.43	2.62	300E	18.9
1-1/2"	5.94*	11.48	7.00	7.00	2.38	2.97	400E	31.45
2"	6.54*	12.17	7.00	7.00	2.38	3.27	675E	34.25

\* DECLUTCHABLE MANUAL OVERRIDE INCLUDED IN DIMENSIONS

### ELECTRIC FEATURES

- 120VAC, 220VAC, 24VAC, 12VDC and 24VDC
- NEMA 4, 4X and 7 housings
- Manual overrides
- Visual indicators
- Open/close or modulating service

FOR NEMA 7 ELECTRIC DIMENSIONS OR OTHER CONFIGURATIONS, CONTACT OUR SALES STAFF.

FOR MORE INFORMATION ON BI-TORQ ACTUATORS, REFER TO OUR INDIVIDUAL PNEUMATIC AND ELECTRIC CATALOGS, OR VISIT BITORQ.COM.

# IS-3W SERIES 3-WAY BALL VALVES

## BILL OF MATERIALS

PART #	NAME	MATERIAL	QTY
1	BODY	316SS	1
2	END CONNECTION	316SS	3
3	BODY SEAL	PTFE	4
4	BALL	316SS	1
5	SEATS	RTFE	4
6	STEM	316SS	1
7	THRUST WASHER	PTFE	1
8	STEM PACKING	PTFE	1
9	GLAND	304SS	1
10	BELLEVILLE WASHER	304SS	2
11	PACKING NUT	304SS	1
12	SPRING WASHER	304SS	1
13	BODY BOLTS	304SS	1
14	BLANK CAP	316SS	1

See page 31 for possible pressure limitations due to flow patterns in certain applications with our floating ball valve design.

## VALVE FEATURES

- 3-Way full port stainless steel valves
- 1/2" through 2" size range
- Ideal for mixing, food and chemical applications
- RTFE® seats and seals
- Threaded or socket weld ends
- 4-seat design for high cycle automation
- Self-adjusting stem packing with belleville washers

**PRESSURE RATING**  
1000 PSI CWP  
**TEMPERATURE RATING**  
+350° F Maximum  
-4° F Minimum

**NOTE: not suitable for vacuum service**

NOTE: MAXIMUM TEMPERATURE RATING FOR STANDARD ACTUATORS IS 150° F (ELECTRIC) AND 180° (PNEUMATIC). SPECIAL SEALS OR HEAT EXTENSIONS ARE AVAILABLE FOR HIGH TEMPERATURE SERVICE.

SEE PAGE 31 FOR AVAILABLE FLOW PATTERNS

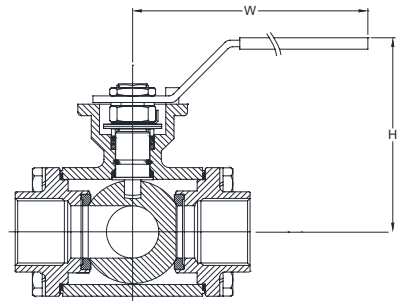
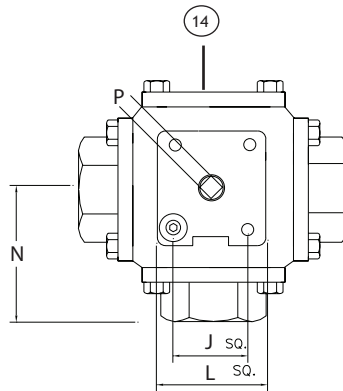
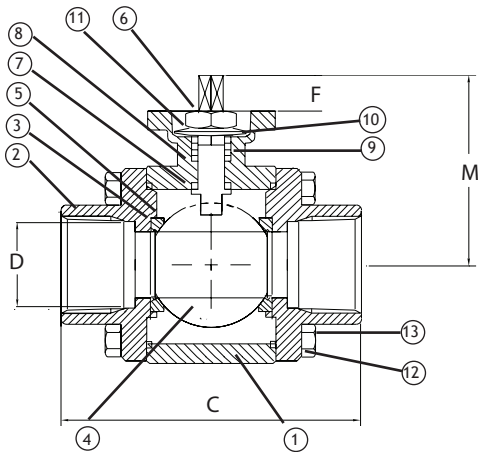

## DIMENSIONAL DATA

SIZE	ISO 5211	B	C	D	F	J	L	M	N	P	W	H	WT.
1/2"	F03-F04	3.50	3.78	0.63	0.35	1.42	1.65	2.24	1.89	0.35	7.34	3.50	3.90
3/4"	F04-F05	3.86	4.21	0.79	0.43	1.65	1.97	2.72	2.11	0.43	8.58	3.86	5.65
1"	F04-F05	4.02	4.96	0.98	0.45	1.65	1.97	2.97	2.48	0.43	8.58	4.02	8.85
1-1/4"	F05-F07	4.67	5.24	1.26	0.60	1.97	2.76	3.71	2.62	0.55	9.25	4.67	11.90
1-1/2"	F05-F07	5.00	5.94	1.50	0.56	1.97	2.76	4.05	2.97	0.55	9.25	5.00	18.45
2"	F07-F10	5.47	6.54	1.97	0.70	2.76	4.02	4.87	3.27	0.67	9.92	5.47	23.25

THE MANUAL VERSION OF THIS MODEL STARTS WITH AN "M"

ALL VALVES ARE 100% ELECTRONICALLY TESTED AT 80 PSI IN BOTH THE OPEN AND CLOSED POSITIONS